

Technical data sheet

Product features



Combi convection steam oven STEAMBOX electric 10x GN 2/1 automatic cleaning boiler 400 V left door

Model	SAP Code	00014900
--------------	-----------------	----------



- Steam type: Symbiotic - boiler and injection combination (patent)
- Number of GN / EN: 10
- GN / EN size in device: GN 2/1
- GN device depth: 65
- Control type: Touchscreen + buttons
- Display size: 9"
- Humidity control: MeteoSystem - regulation based on direct measurement of humidity in the chamber (patented)
- Advanced moisture adjustment: Steamtuner - 5-stage system of setting steam saturation by controlled combination of production by boiler or injection
- Delta T heat preparation: Yes
- Automatic preheating: Yes
- Multi level cooking: Drawer program - control of heat treatment for each dish separately
- Door constitution: Vented safety double glass, removable for easy cleaning

SAP Code	00014900	Steam type	Symbiotic - boiler and injection combination (patent)
Net Width [mm]	1120	Number of GN / EN	10
Net Depth [mm]	845	GN / EN size in device	GN 2/1
Net Height [mm]	1115	GN device depth	65
Net Weight [kg]	220.00	Control type	Touchscreen + buttons
Power electric [kW]	28.300	Display size	9"
Loading	400 V / 3N - 50 Hz		

Technical data sheet

Technical drawing



Combi convection steam oven STEAMBOX electric 10x GN 2/1 automatic cleaning boiler 400 V left door

Model

SAP Code

00014900

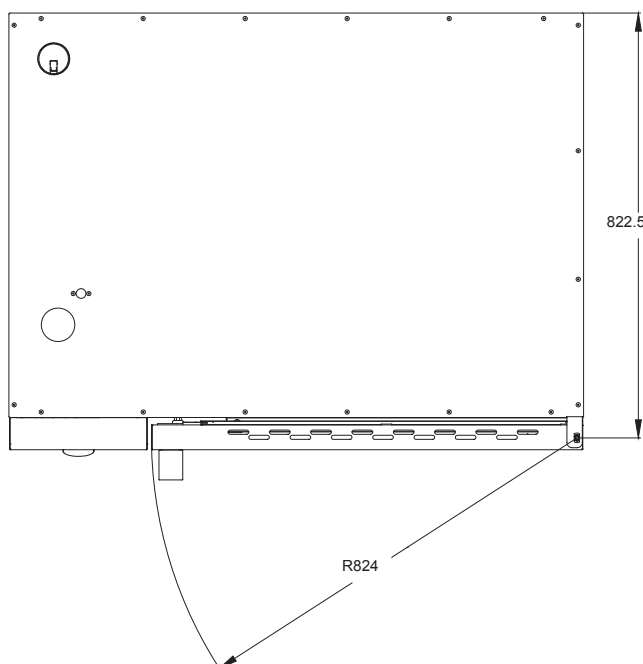
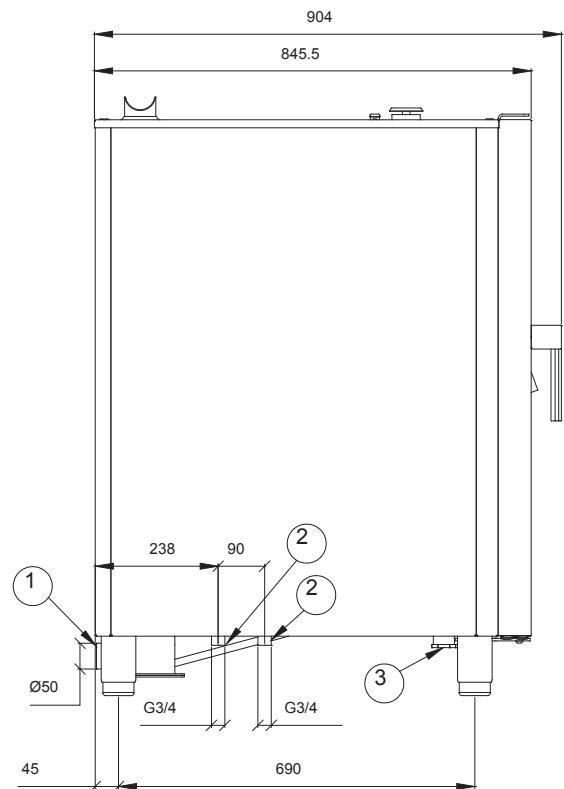
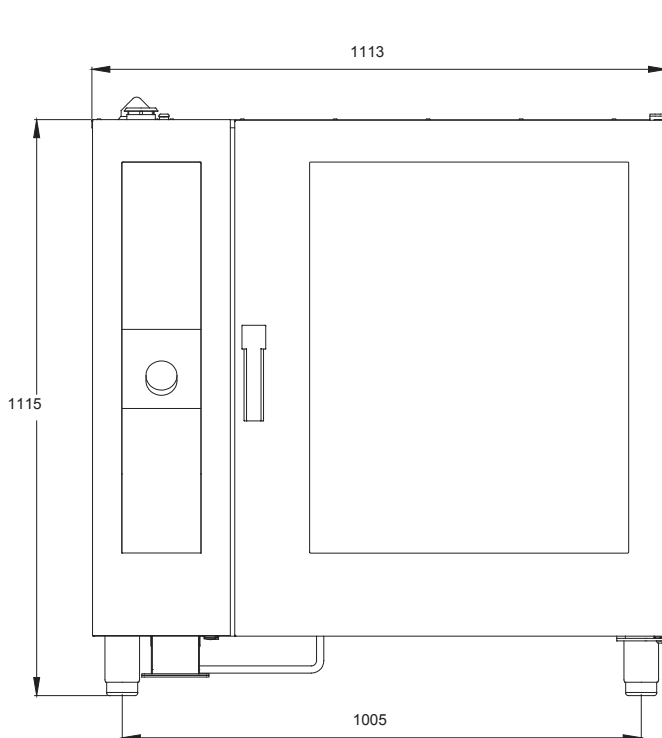

- ① DRAIN
- ② WATER INLET
- ③ POWER SUPPLY

Technical data sheet

Technical parameters



Combi convection steam oven STEAMBOX electric 10x GN 2/1 automatic cleaning boiler 400 V left door

Model

SAP Code

00014900

1. SAP Code:

00014900

2. Net Width [mm]:

1120

3. Net Depth [mm]:

845

4. Net Height [mm]:

1115

5. Net Weight [kg]:

220.00

6. Gross Width [mm]:

1320

7. Gross depth [mm]:

1130

8. Gross Height [mm]:

1240

9. Gross Weight [kg]:

230.00

10. Device type:

Electric unit

11. Power electric [kW]:

28.300

12. Loading:

400 V / 3N - 50 Hz

13. Material:

AISI 304

14. Exterior color of the device:

Stainless steel

15. Adjustable feet:

Yes

16. Humidity control:

MeteoSystem - regulation based on direct measurement of humidity in the chamber (patented)

17. Stacking availability:

Yes

18. Control type:

Touchscreen + buttons

19. Additional information:

Version with left door (hinges on the left, handle on the right)

20. Steam type:

Symbiotic - boiler and injection combination (patent)

21. Chimney for moisture extraction:

Yes

22. Delayed start:

Yes

23. Display size:

9"

24. Delta T heat preparation:

Yes

25. Automatic preheating:

Yes

26. Automatic cooling:

Yes

Technical data sheet

Technical parameters



Combi convection steam oven STEAMBOX electric 10x GN 2/1 automatic cleaning boiler 400 V left door

Model	SAP Code	00014900
--------------	-----------------	----------

27. Cold smoke-dry function:

Yes

28. Unified finishing of meals EasyService:

Yes

29. Night cooking:

Yes

30. Washing system:

Closed - efficient use of water and washing chemicals by repeated pumping

31. Detergent type:

Liquid washing detergent + liquid rinse aid/vinegar or washing tablets

32. Multi level cooking:

Drawer program - control of heat treatment for each dish separately

33. Advanced moisture adjustment:

Steamtuner - 5-stage system of setting steam saturation by controlled combination of production by boiler or injection

34. Slow cooking:

from 30 °C - the possibility of rising

35. Fan stop:

Immediate when the door is opened

36. Lighting type:

LED lighting in the doors, on both sides

37. Cavity material and shape:

AISI 304, with rounded corners for easy cleaning

38. Reversible fan:

Yes

39. Sustance box:

Yes

40. Heating element material:

Incoloy

41. Probe:

Yes

42. Shower:

Hand winder

43. Distance between the layers [mm]:

70

44. Smoke-dry function:

Yes

45. Interior lighting:

Yes

46. Low temperature heat treatment:

Yes

47. Number of fans:

1

48. Number of fan speeds:

6

49. Number of programs:

1000

50. USB port:

Yes, for uploading recipes and updating firmware

51. Door constitution:

Vented safety double glass, removable for easy cleaning

52. Number of preset programs:

100

Technical data sheet

Technical parameters



Combi convection steam oven STEAMBOX electric 10x GN 2/1 automatic cleaning boiler 400 V left door

Model

SAP Code

00014900

53. Number of recipe steps:

9

54. Minimum device temperature [°C]:

30

55. Maximum device temperature [°C]:

300

56. Device heating type:

Combination of steam and hot air

57. HACCP:

Yes

58. Number of GN / EN:

10

59. GN / EN size in device:

GN 2/1

60. GN device depth:

65

61. Food regeneration:

Yes

62. Cross-section of conductors CU [mm²]:

10

- Výkon (kW): 5,7-6,6 (230 V); 9,8-11 (400 V)

63. Diameter nominal:

DN 50

64. Water supply connection:

3/4"